



Smart Production – On The Way To Autonomous Laser Processes

Dr. Rüdiger Brockmann | Industry- / Product Management & Marketing
08.05.2019

Agenda

01 TRUMPF

02 Intelligent Equipment

03 Intelligent Processes

04 Networks

05 Artificial Intelligence

06 Conclusion

Building blocks for
autonomous processing

Intelligent Equipment

Condition Data / Health
Check

Intelligent Processes

Process Data / Assistance
Systems

Networks

Communication

Artificial Intelligence

Agenda

01 TRUMPF

02 Intelligent Equipment

03 Intelligent Processes

04 Networks

05 Artificial Intelligence

06 Conclusion

TRUMPF Group

FY 2017 / 2018

Sales 2017/18

3,566 in mil. €
+14.6 %

R+D expenditures in mil. €

337

Employees on June 30, 2018

13,420

R+D quota

9.5 %

Business Fields

Revenue in FY 2017/18

Machine tools for flexible sheet processing



Revenue 2017/18

3,02 Mrd. €
+11,3%

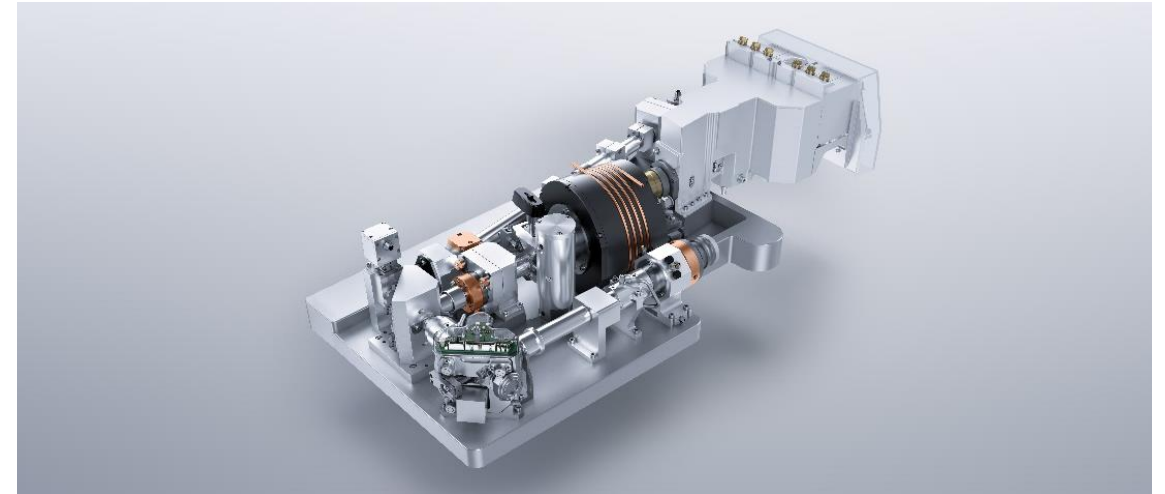

Revenue 2017/2018

1,50 Mrd. €
+21,5%

Global Presence

Worldwide with our customers at 66 locations

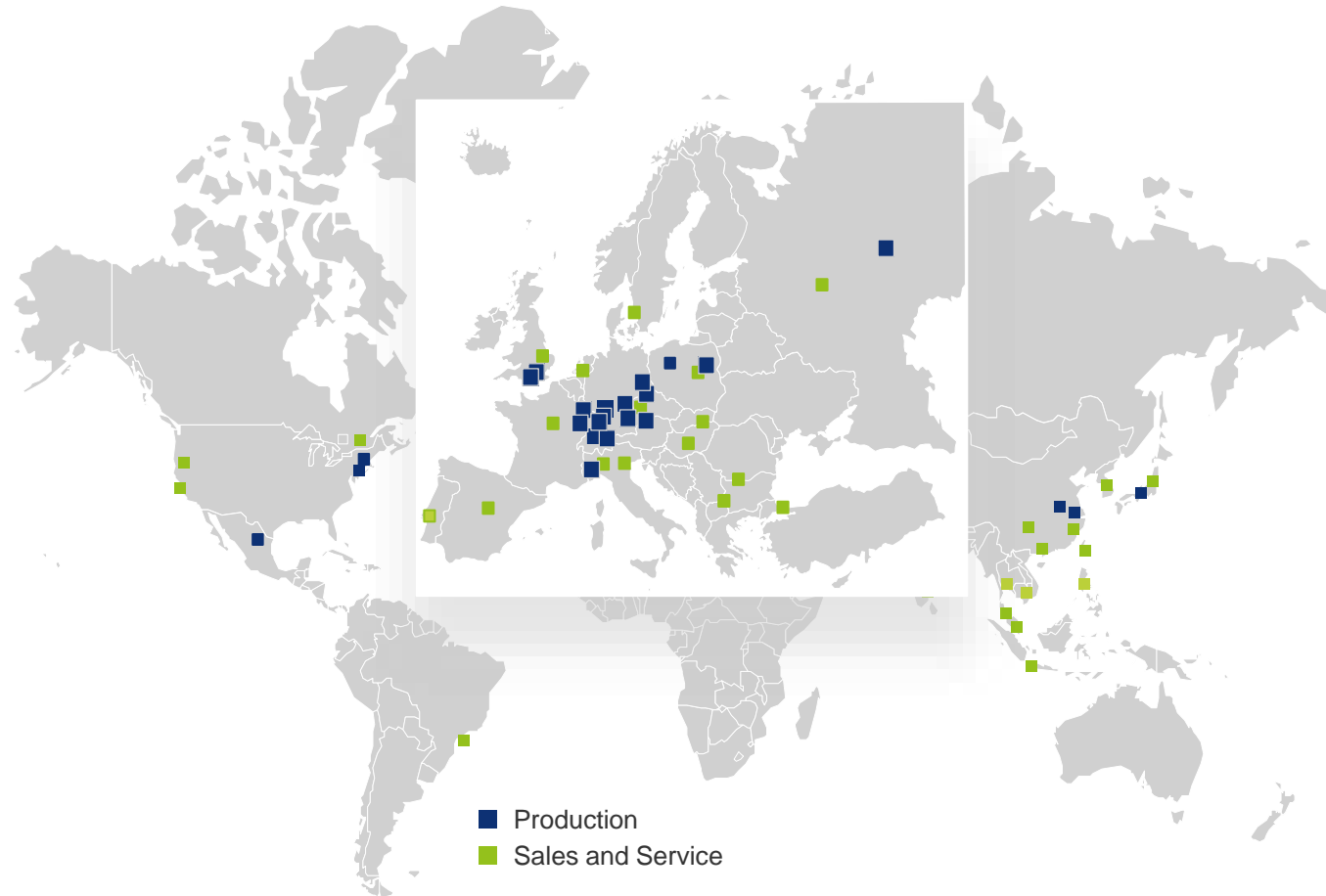

Driven by technology ...

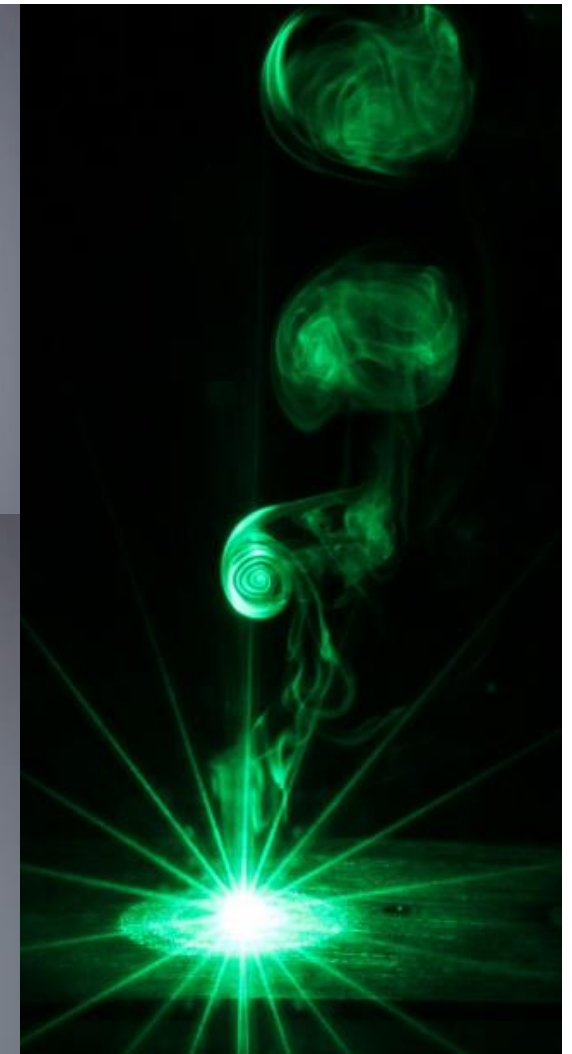
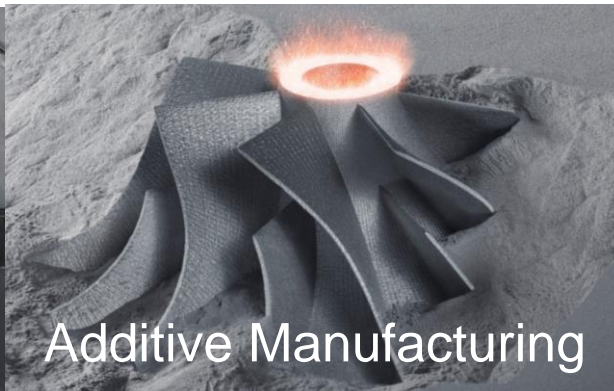
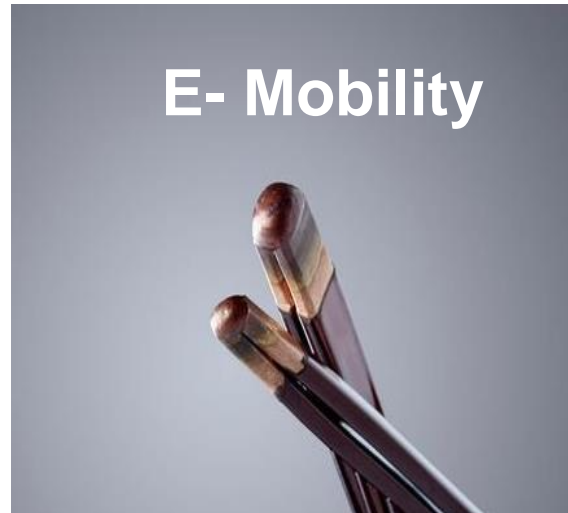
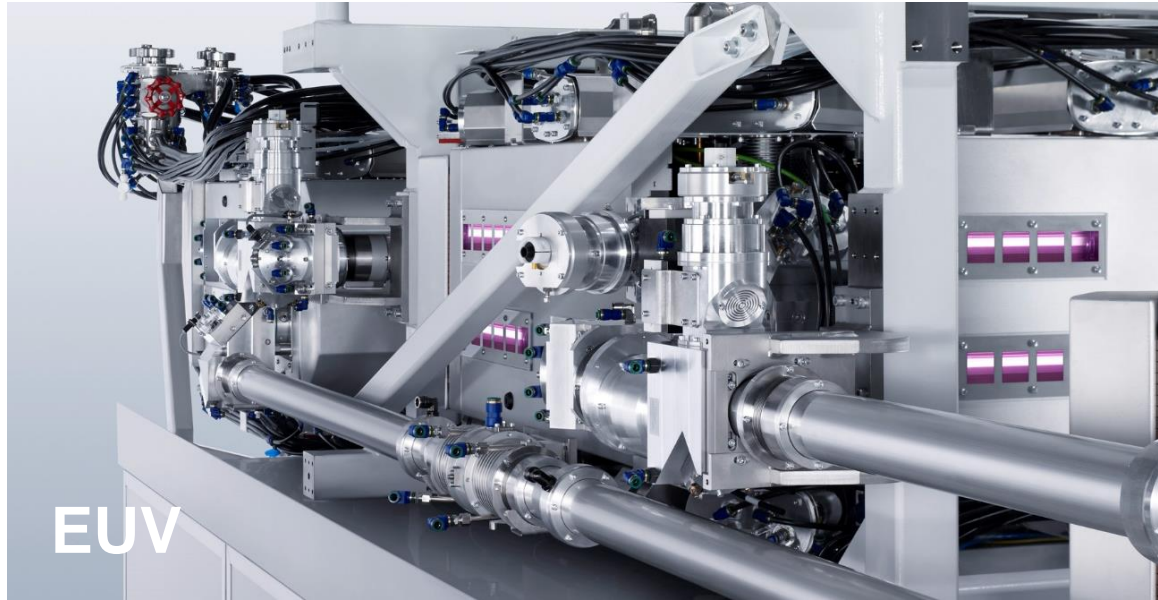

The story of autonomous driving ...

... a parallelity to autonomous laser processes?

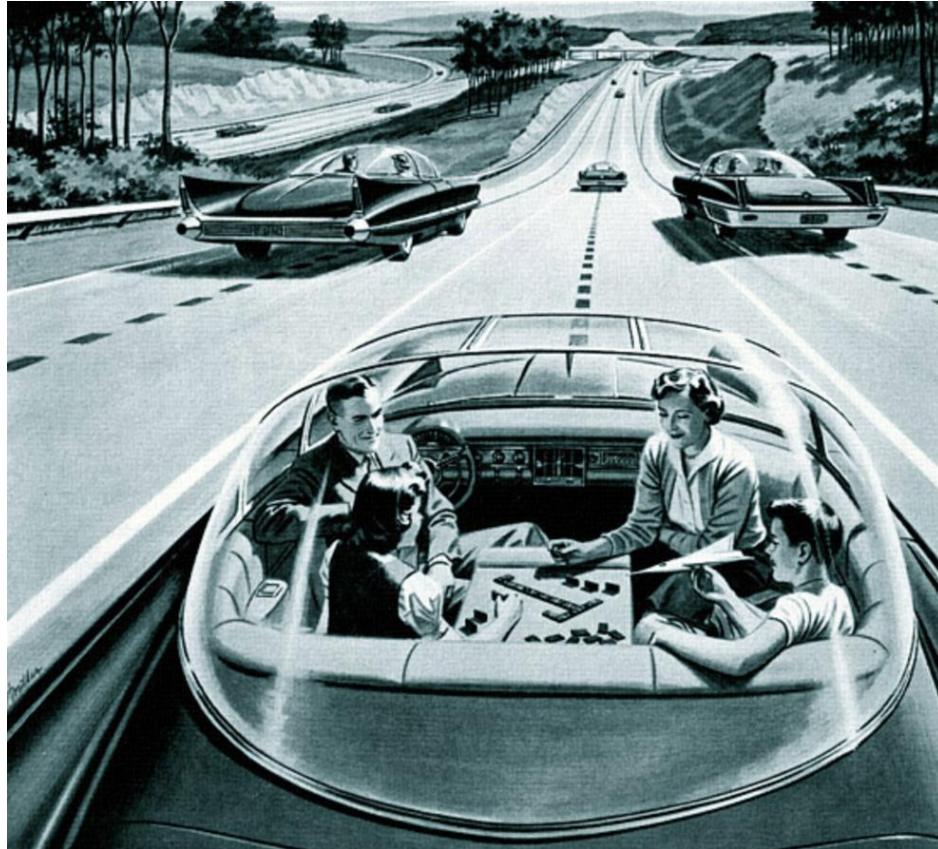

*America's Power Companies' advertisement from 1956 depicting a future with autonomous cars. **

* <https://www.engineering.com/DesignerEdge/DesignerEdgeArticles/ArticleID/12665/The-Road-to-Driverless-Cars-1925--2025.aspx>



<https://phys.org/news/2018-06-demystifying-future-autonomous-vehicles.html>



<https://sanfrancisco.cbslocal.com/2018/06/07/ntsb-driver-fatal-tesla-crash/>



<https://medium.com/@DonotInnovate/mind-blowing-driverless-future-fcc5197d509>

Agenda

01 TRUMPF

02 Intelligent Equipment

03 Intelligent Processes

04 Networks

05 Artificial Intelligence

06 Conclusion



Intelligent Laser systems, optics and sensors provide data

With Condition & Data Based Services we are able to utilize these data



Intelligent laser source



Smart laser light cables



Intelligent scanner optics (PFO)

Overview Laserpool
Maintenance Calendar
Messages & Alarms
Modification of programs
Rule Management

Drill Down of Single Laser

Smart View Services

Dashboards:

- Status of Laser
- Messages / Alarms
- Modifications of programs
- Maintenance Calendar
- Connectivity Status

Condition Monitoring / Predictive Maintenance for higher availability

Smart algorithms and TRUMPF experts monitor your condition data



Condition Monitoring / Predictive Maintenance for higher availability

Case Study: Early detection of increasing sensor values

Early detection of production interruptions

- Trend analysis showed increasing values of scattered light
- Service expert contacted customer proactively
- Identification of back reflections caused by welding of aluminum with filler wire
→ Root cause: Operator has changed angle of focusing optic

Benefit

- Based on the analysis and discussion with the service expert a quick solution was found
→ Realignment of focusing optic
- Successful avoidance of downtime
→ Cost savings
→ No production interruption

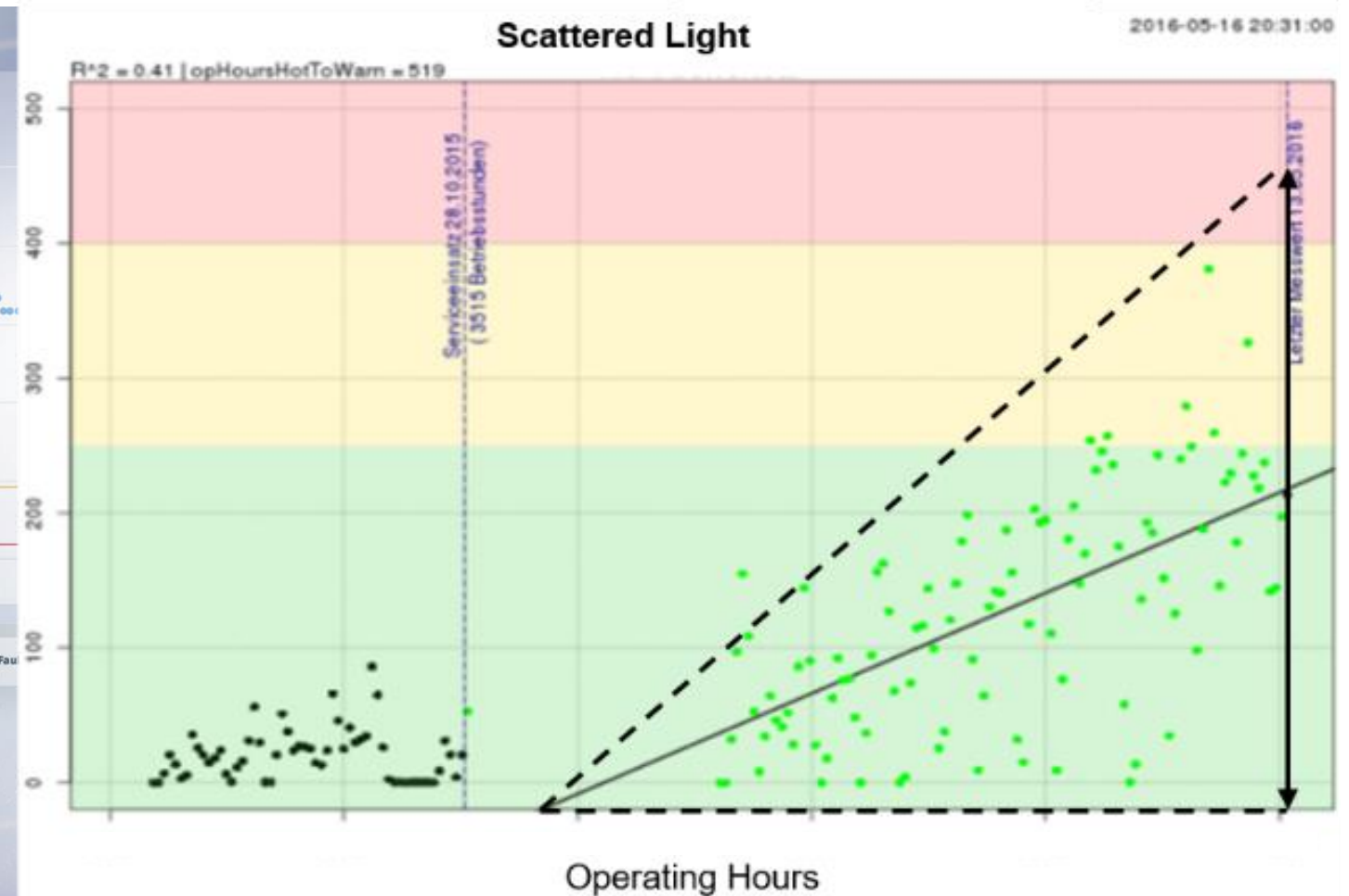

Condition Monitoring / Predictive Maintenance for higher availability

Case Study: Early identification of operating errors and improvement potential

Early detection of production interruptions

- Analysis of data showed low measured values for conductivity → Indicator for missing copper care
- Problem: Customer forgot to add copper care at several refills of cooling water

Benefit

- Avoidance of cost-intensive spare parts & service mission
→ missing copper care might cause corrosion at the cooling fingers
- Identification of necessary training for operators / maintenance

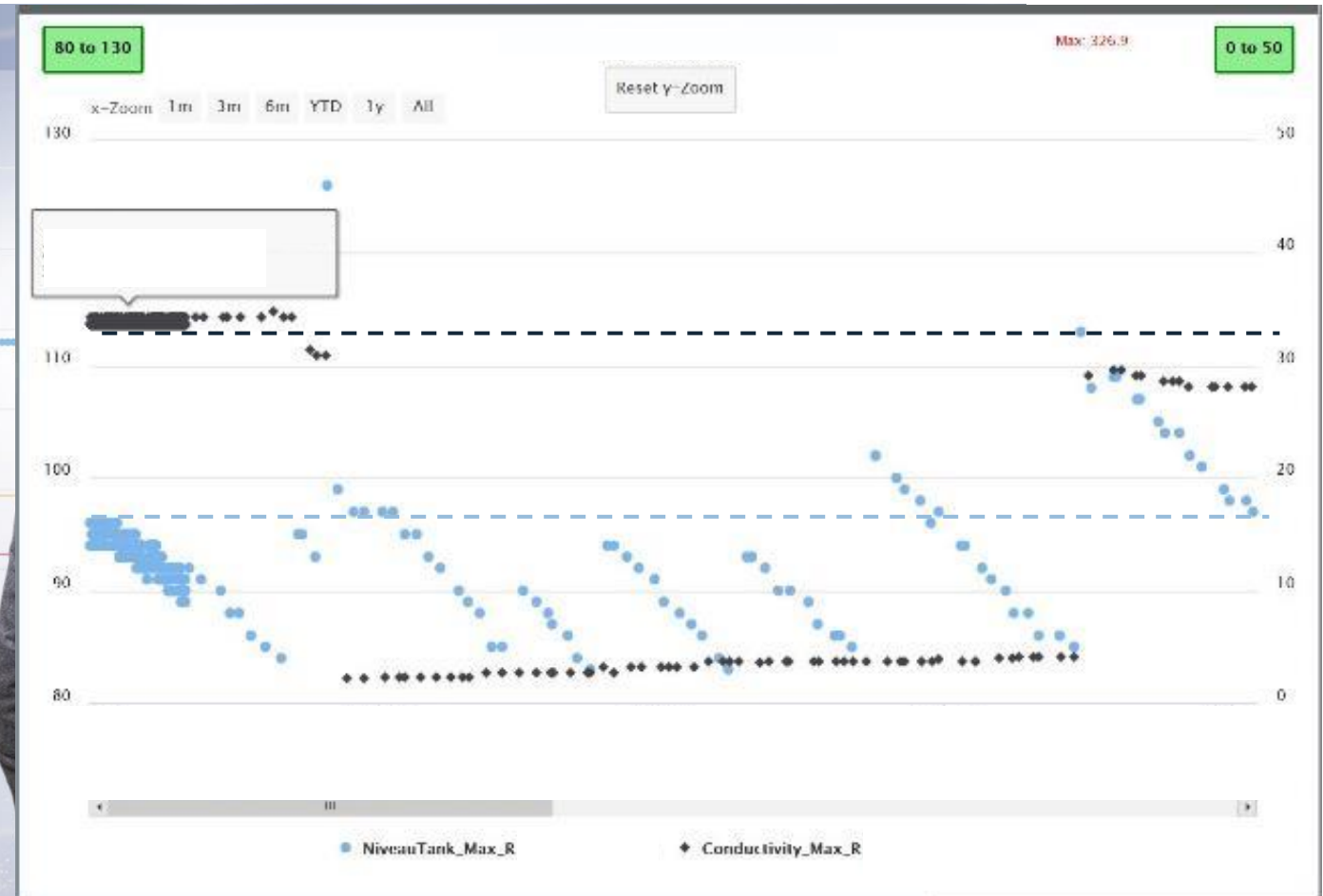

Agenda

01 TRUMPF

02 Intelligent Equipment

03 Intelligent Processes

04 Networks

05 Artificial Intelligence

06 Conclusion



Seam Line Remote

Intelligent Sensor System for Pathfinding

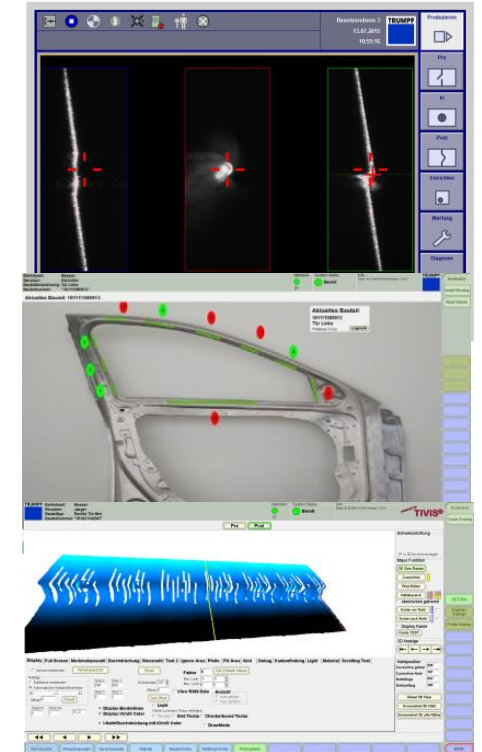
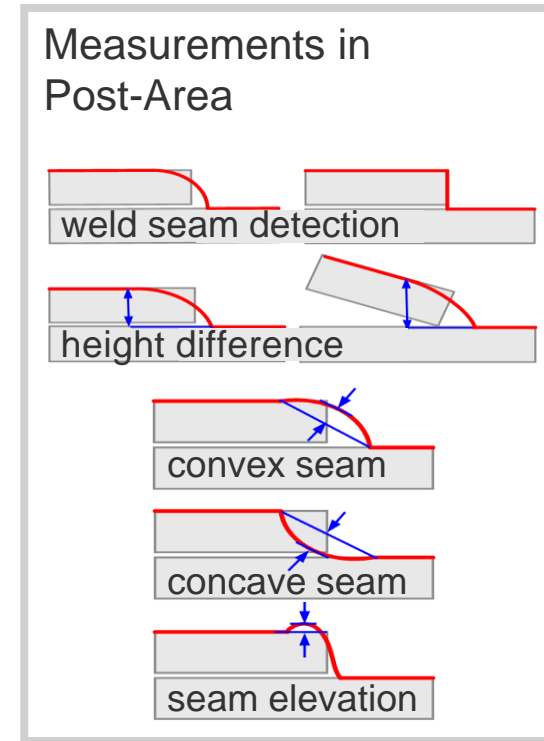
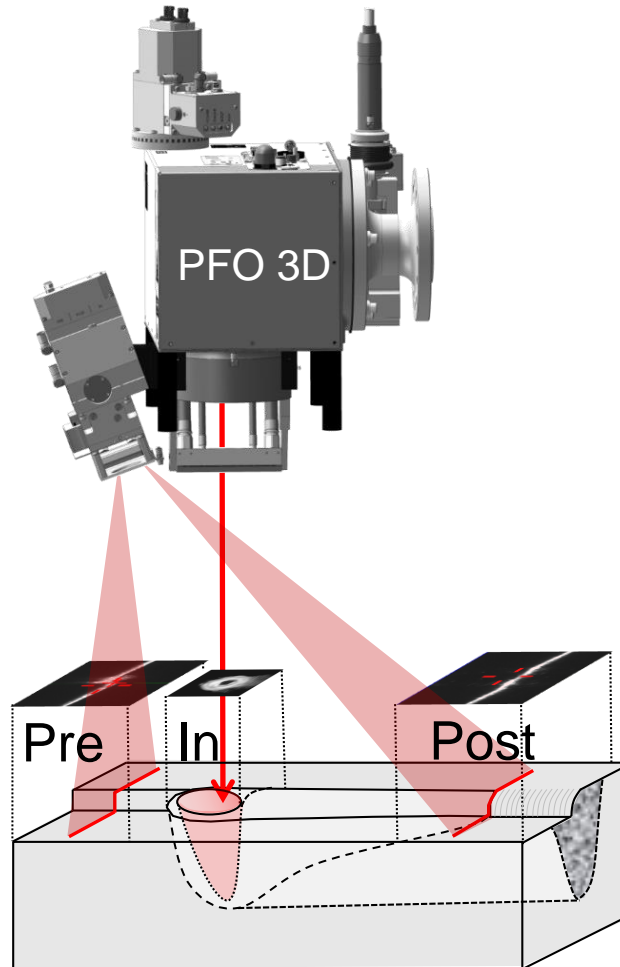
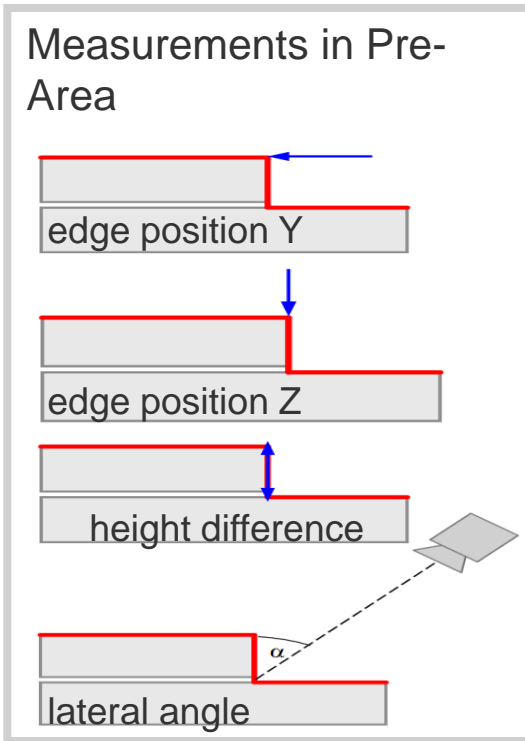

Richtungsunabhängiges Kehlnahtschweißen mit OCT-Nahtlagerregelung

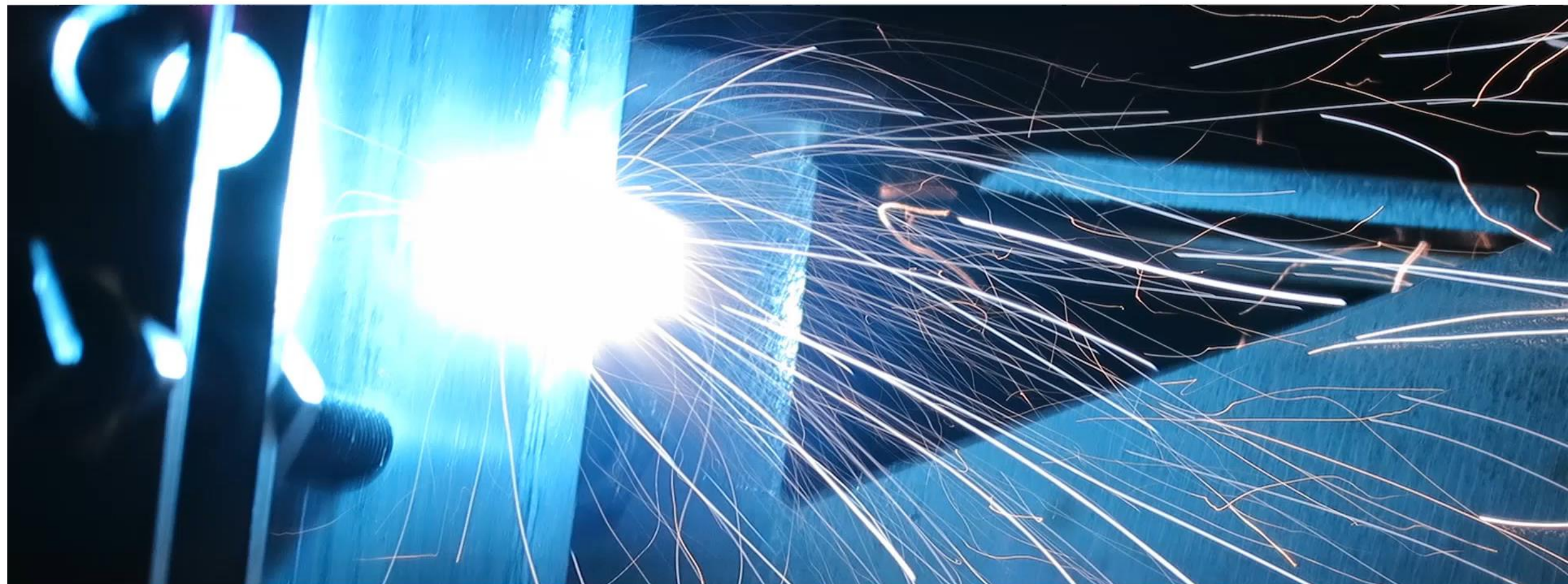

Agenda

- 01 TRUMPF
- 02 Intelligent Equipment
- 03 Intelligent Processes
- 04 Networks
- 05 Artificial Intelligence
- 06 Conclusion



Industry 4.0: Horizontal and vertical network approach at TRUMPF

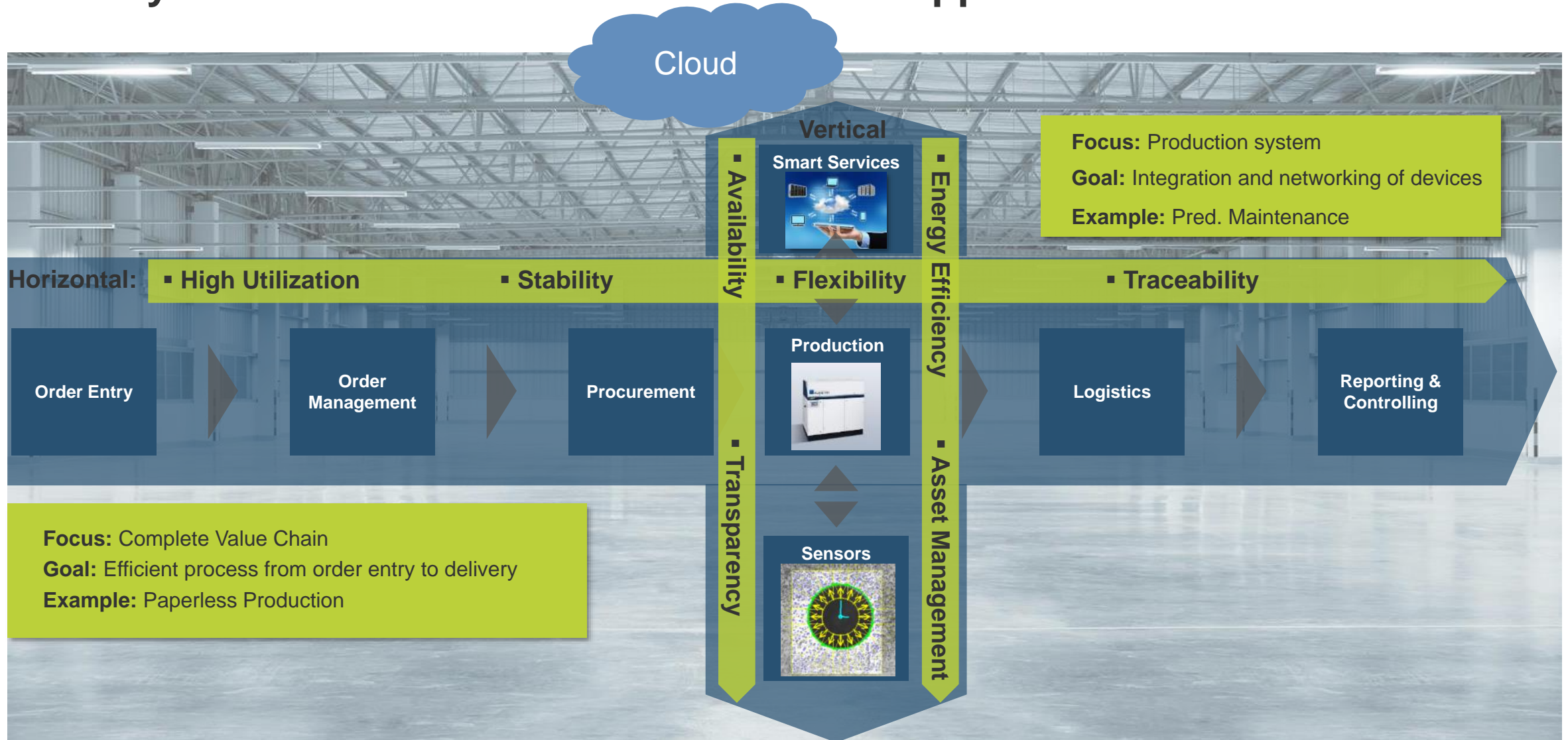

TruConnect: Networks capabilities on different levels – an overview

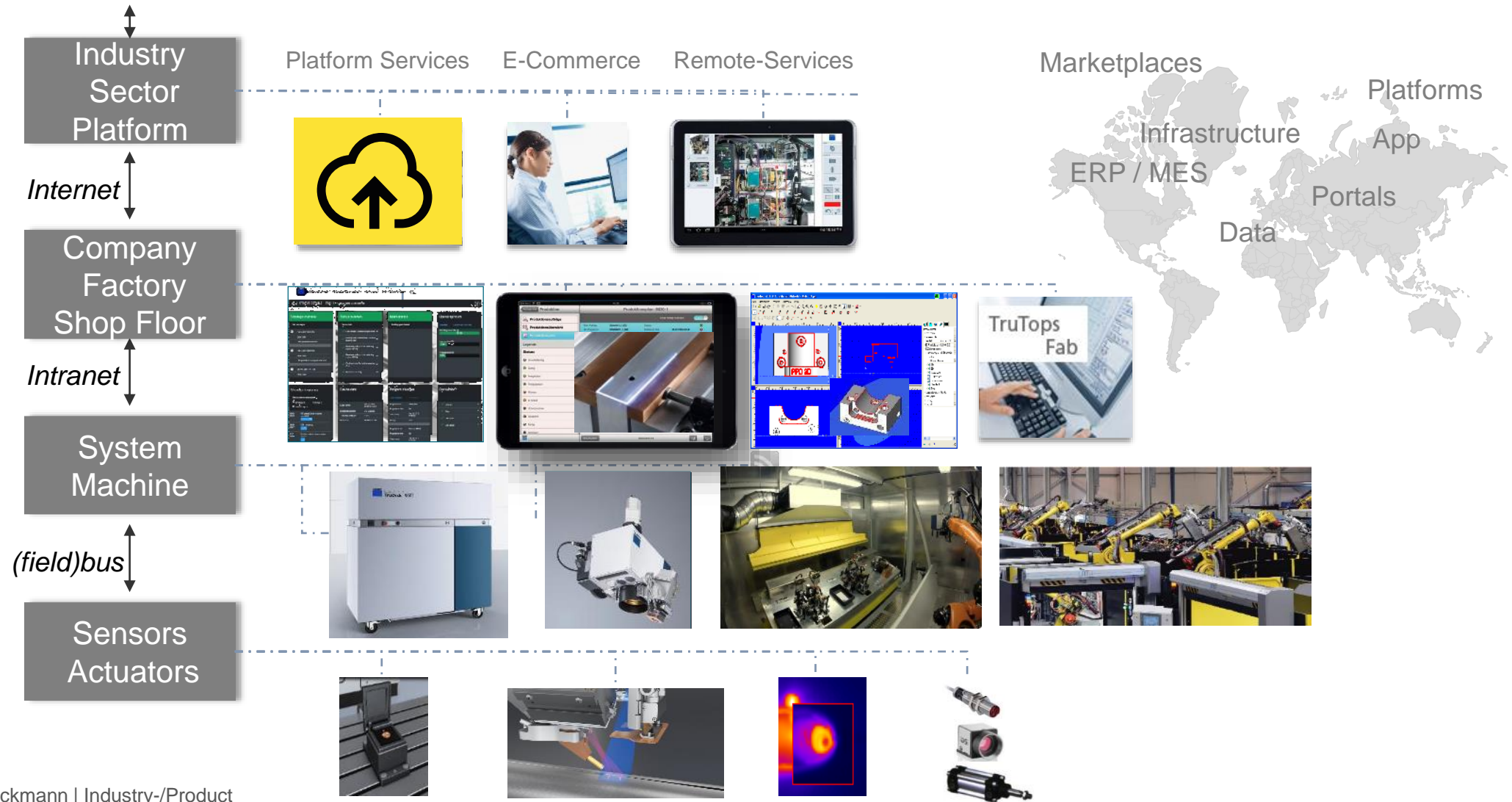

Take full advantage by using cloud based solutions

Example of IT-Infrastructure for data transfer

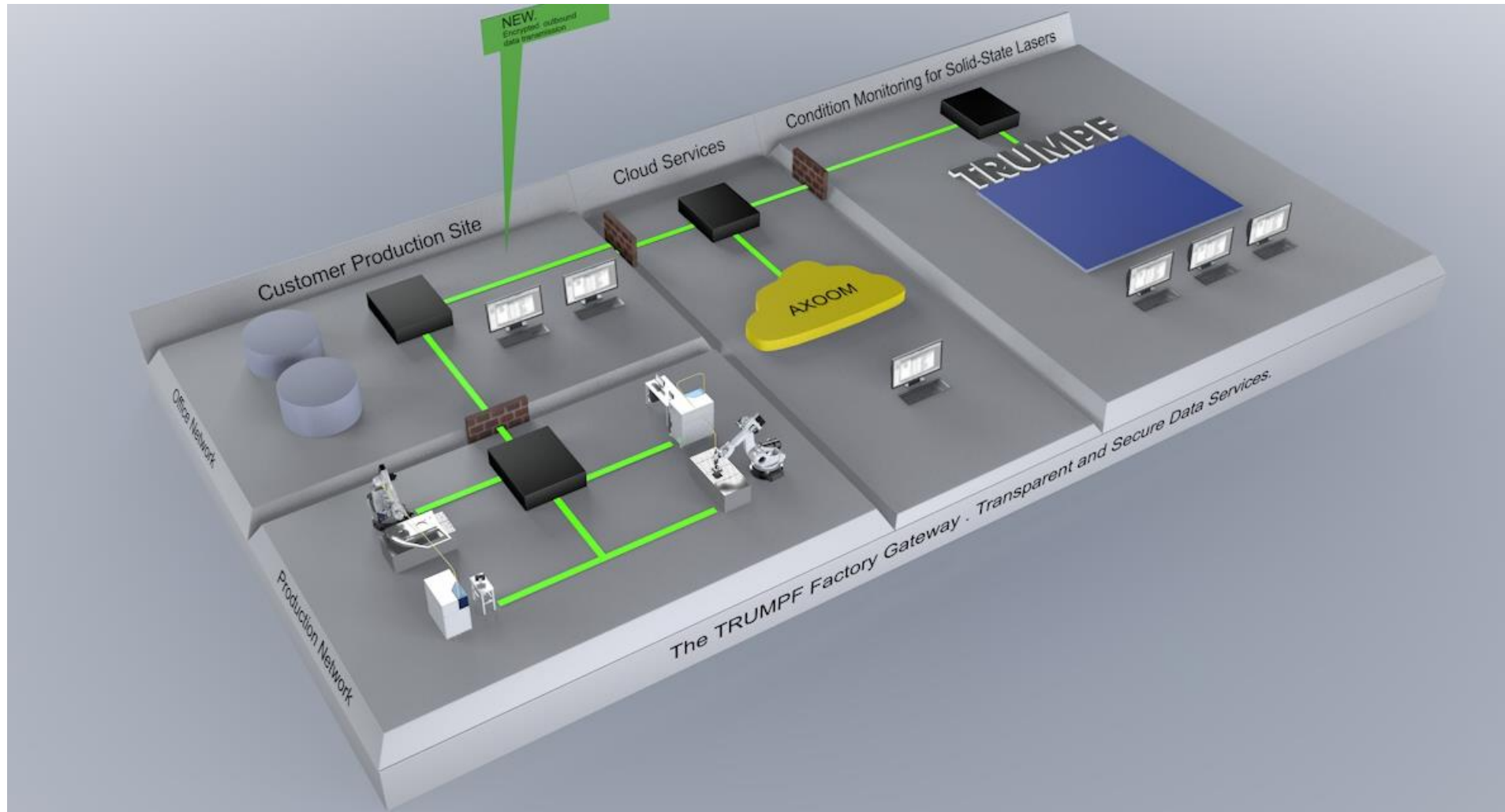

Factory Gate / Cloud Gate powered by C-Labs:



Cooperation is the key factor for success of Industry 4.0

Connectivity as crucial basis for Industry 4.0 benefits

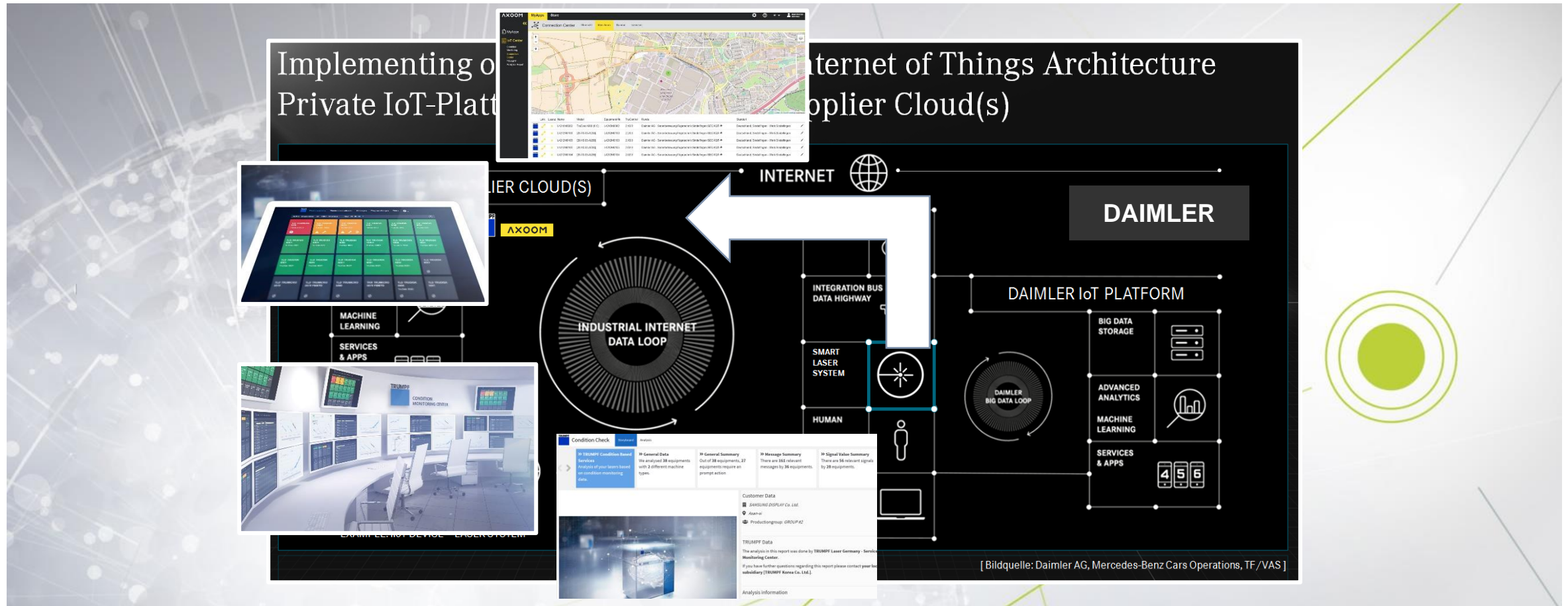

Agenda

01 TRUMPF

02 Intelligent Equipment

03 Intelligent Processes

04 Networks

05 Artificial Intelligence

06 Conclusion

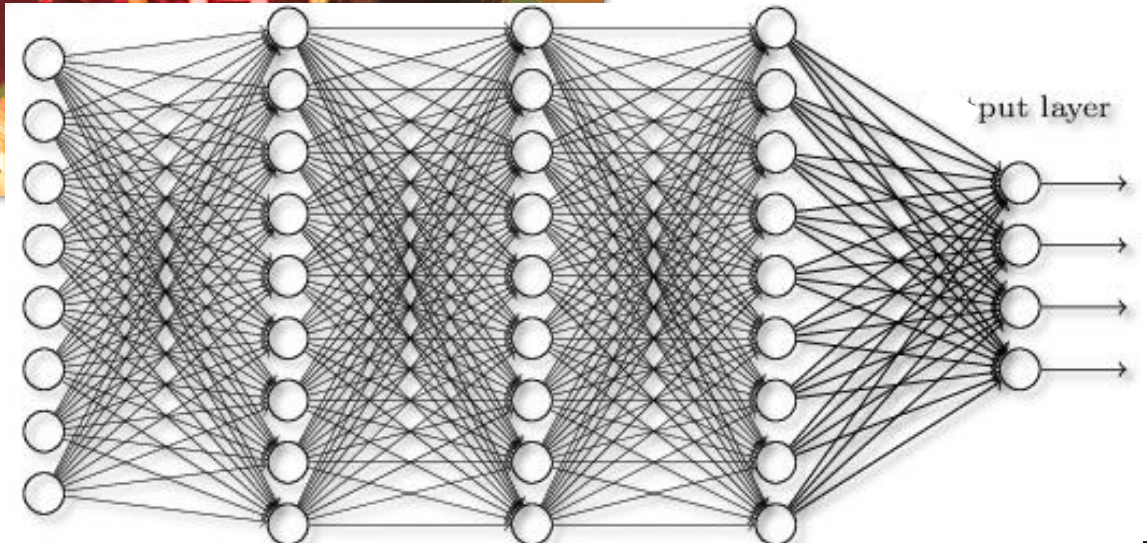
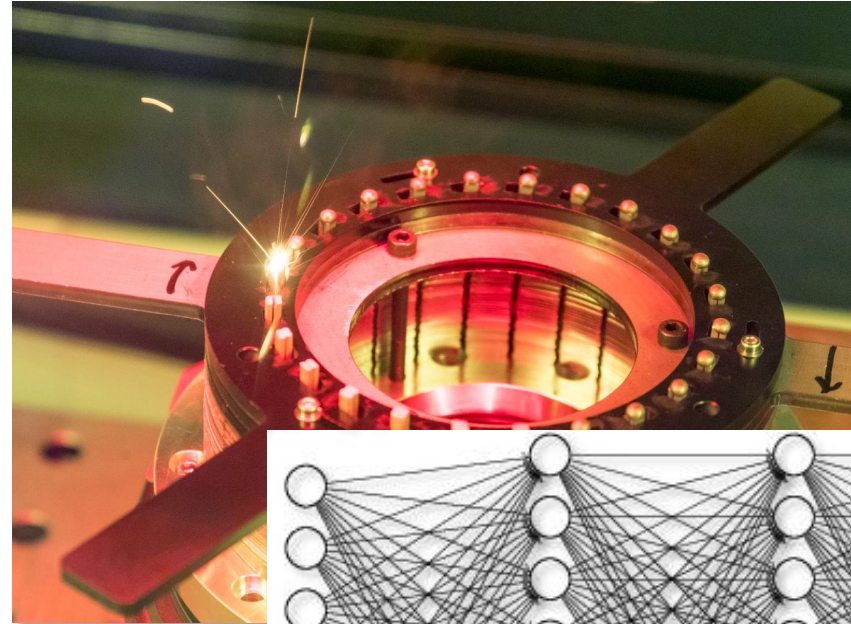
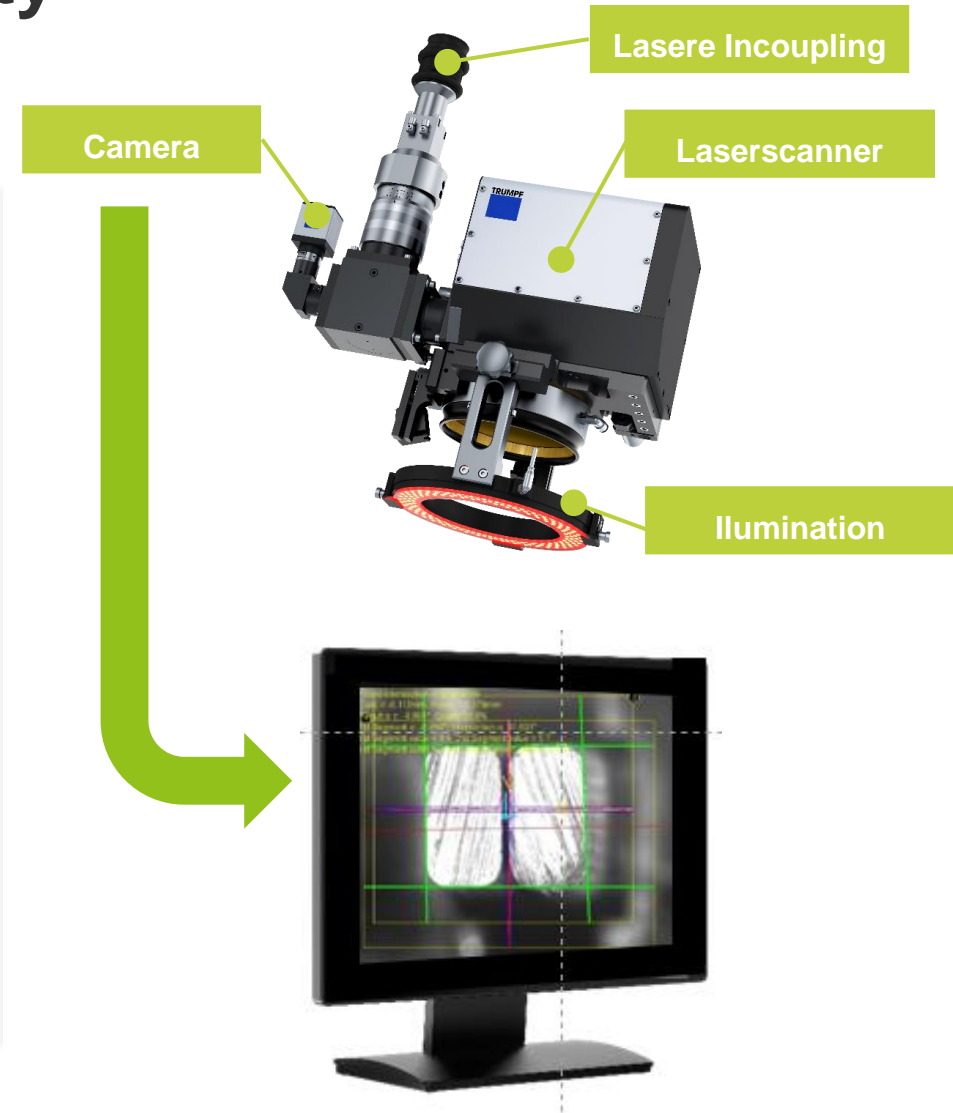
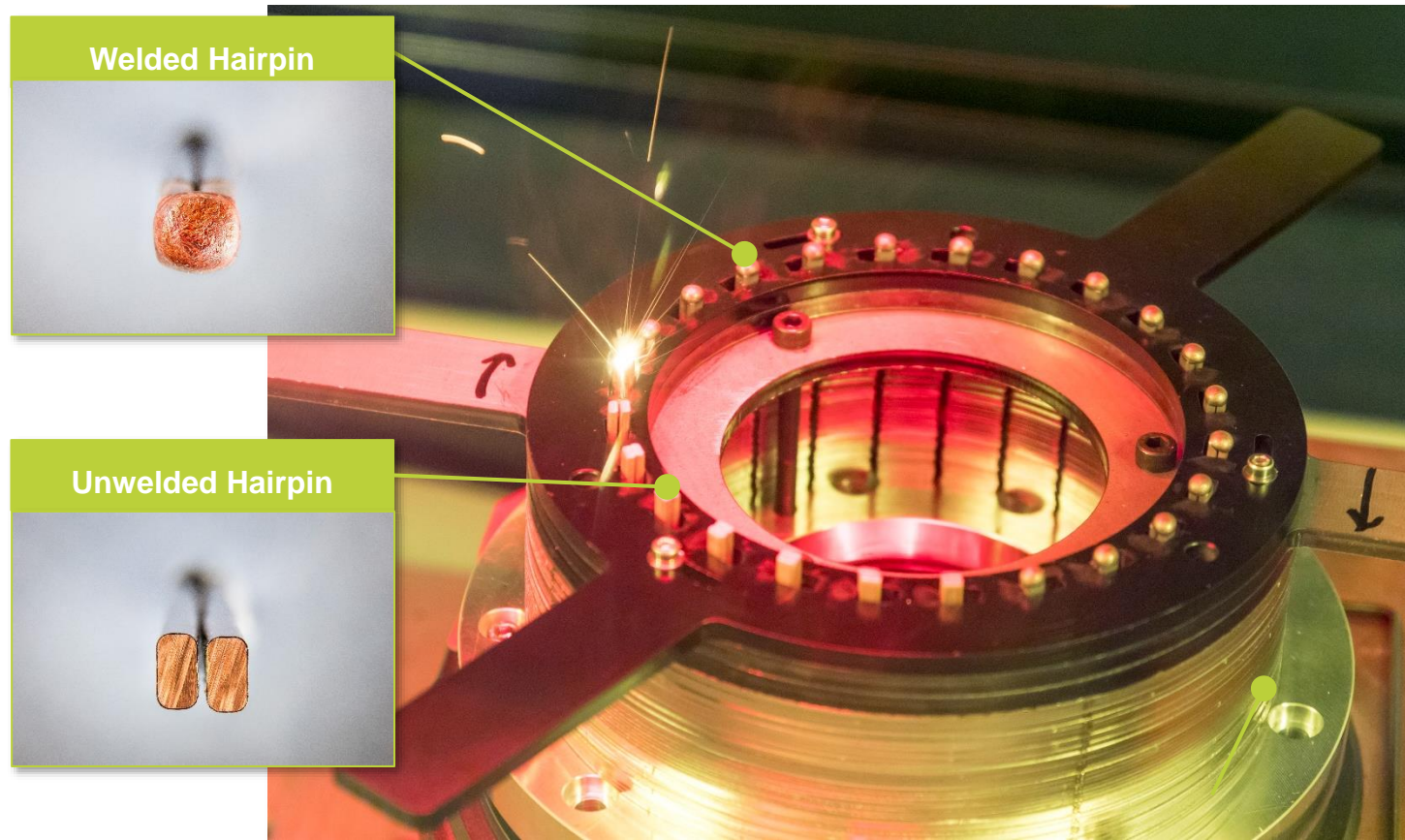

Image:
<https://datawarrior.wordpress.com/2017/10/31/interpretability-of-neural-networks/>

Laser Hairpin Welding for Electro- Mobility



Recognize difficult preconditions / The right welding position

Image processing does recognize gap & shift

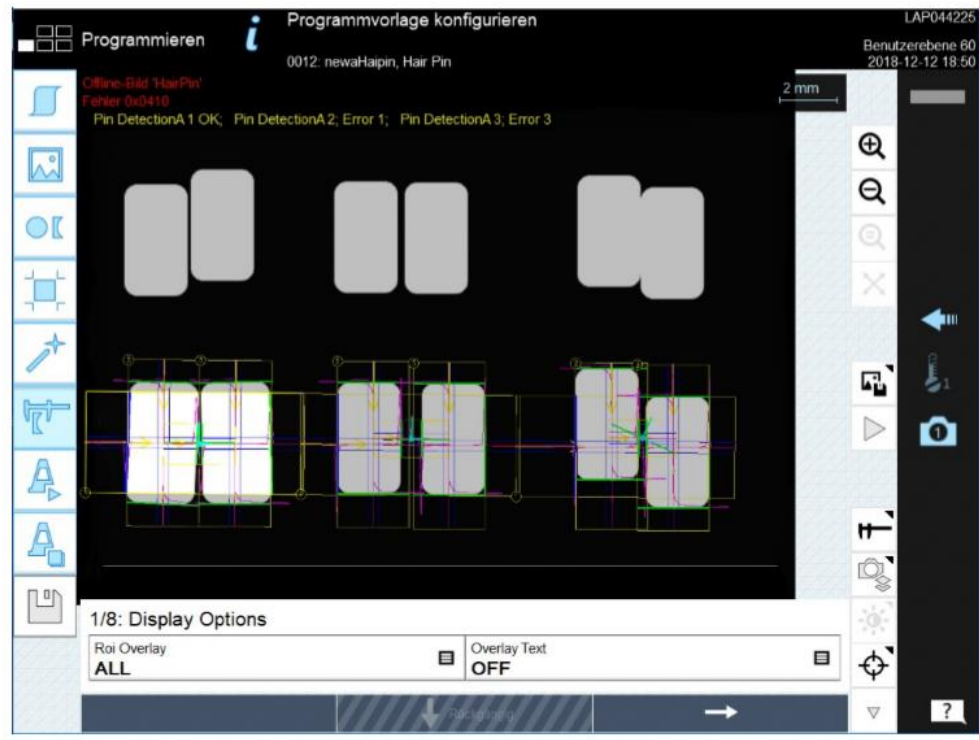

Location data for welding is transferred to scanner head



Artificial Intelligence enables new possibilities

Neural networks have to be trained

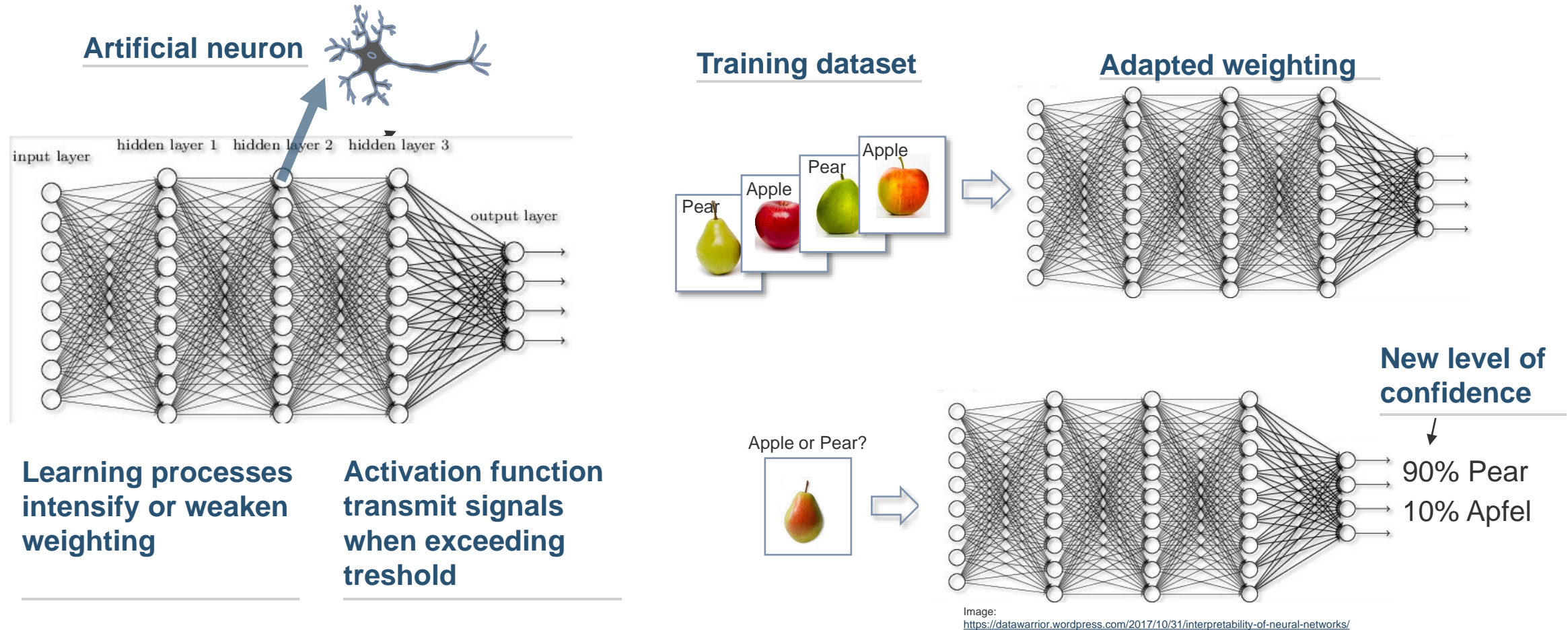

Application of deep learning in quality control

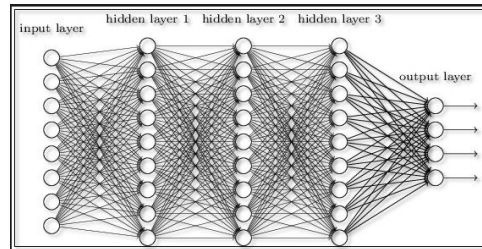
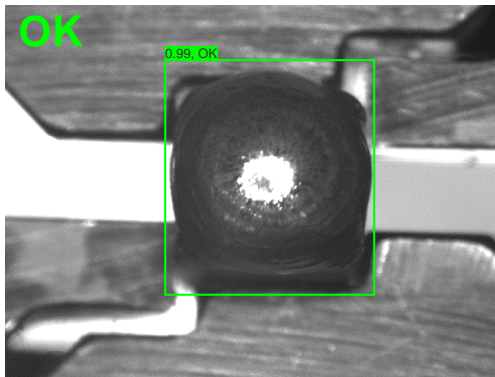
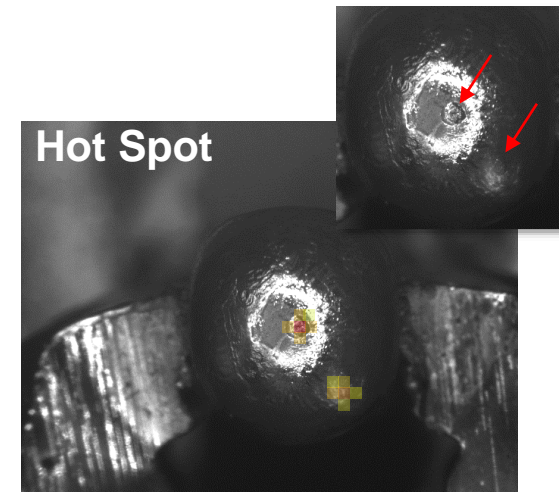
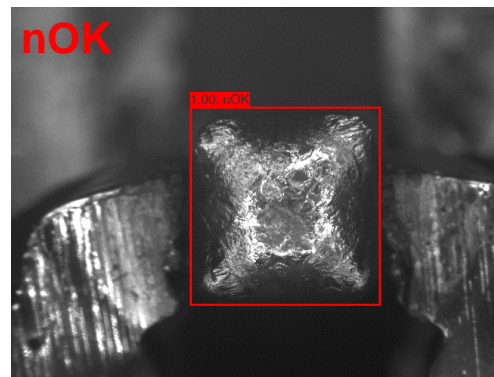

Image: <https://datawarrior.wordpress.com/2017/10/31/interpretability-of-neural-networks/>



Images courtesy of Grob-Werke GmbH & Co. KG



Agenda

- 01 TRUMPF
- 02 Intelligent Equipment
- 03 Intelligent Processes
- 04 Networks
- 05 Artificial Intelligence
- 06 Conclusion



Vision: Autonomous laser based production

Comparison to autonomous driving

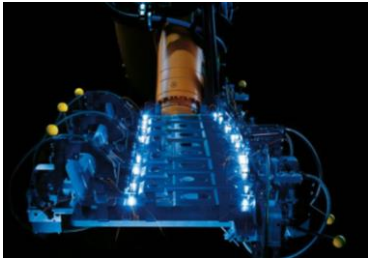
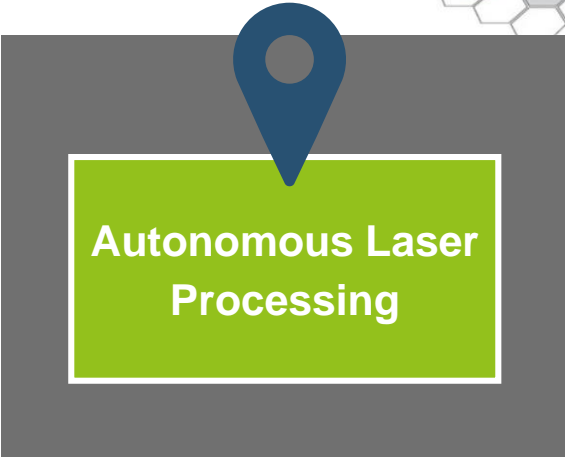
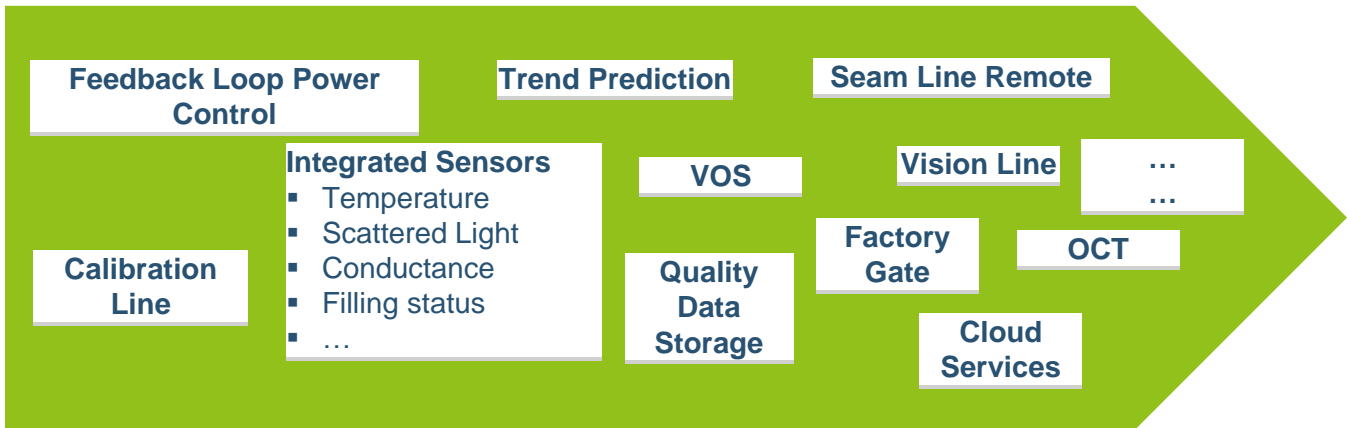
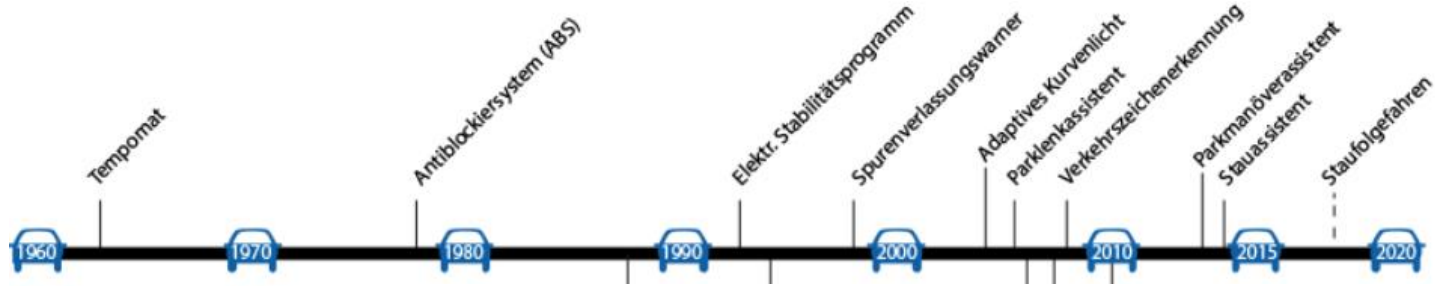



On the way to autonomous laser processing:

Not yet arrived,

but already added value!!!

Rüdiger Brockmann

ruediger.brockmann@trumpf.com